

LIL:CS:IP:2021-22

Date: 11.02.2022

| | |
|--|--|
| BSE Limited Listing & Compliance Department Phiroze Jeejeebhoy Towers, Dalal Street, Mumbai - 400001 | The National Stock Exchange of India Limited Listing & Compliance Department Exchange Plaza, C-1 Block G, Bandra Kurla Complex, Bandra (E), Mumbai – 400051 |
| Security Code : 517206 | Symbol: LUMAXIND |

Subject: Investor Presentation for the 3rd Quarter and Nine Months ended 31st December, 2021.

Dear Sir/ Ma'am,

Please find enclosed herewith the Investor Presentation of the Company for the 3rd Quarter and Nine Months ended 31st December, 2021.

The same shall also be made available on the website of the Company www.lumaxworld.in/lumaxindustries.

This is for your information and records.

Thanking you,

Yours faithfully,

For LUMAX INDUSTRIES LIMITED



PANKAJ MAHENDRU
COMPANY SECRETARY
M. NO. A-28161



Encl: As Stated above



Lumax Industries Limited

Investor Presentation – Q3 FY21-22



This presentation and the accompanying slides (the “Presentation”), which have been prepared by **Lumax Industries Limited** (the “Company”), have been prepared solely for information purposes and do not constitute any offer, recommendation or invitation to purchase or subscribe for any securities, and shall not form the basis or be relied on in connection with any contract or binding commitment whatsoever. No offering of securities of the Company will be made except by means of a statutory offering document containing detailed information about the Company.

This Presentation has been prepared by the Company based on information and data which the Company considers reliable, but the Company makes no representation or warranty, express or implied, whatsoever, and no reliance shall be placed on the truth, accuracy, completeness, fairness and reasonableness of the contents of this Presentation. This Presentation may not be all inclusive and may not contain all of the information that you may consider material. Any liability in respect of the contents of, or any omission from, this Presentation is expressly excluded.

Certain matters discussed in this Presentation may contain statements regarding the Company’s market opportunity and business prospects that are individually and collectively forward-looking statements. Such forward-looking statements are not guarantees of future performance and are subject to known and unknown risks, uncertainties and assumptions that are difficult to predict. These risks and uncertainties include, but are not limited to, the performance of the Indian economy and of the economies of various international markets, the performance of the industry in India and world-wide, competition, the company’s ability to successfully implement its strategy, the Company’s future levels of growth and expansion, technological implementation, changes and advancements, changes in revenue, income or cash flows, the Company’s market preferences and its exposure to market risks, as well as other risks. The Company’s actual results, levels of activity, performance or achievements could differ materially and adversely from results expressed in or implied by this Presentation. The Company assumes no obligation to update any forward-looking information contained in this Presentation. Any forward-looking statements and projections made by third parties included in this Presentation are not adopted by the Company and the Company is not responsible for such third party statements and projections.



Lumax-DK Jain Group



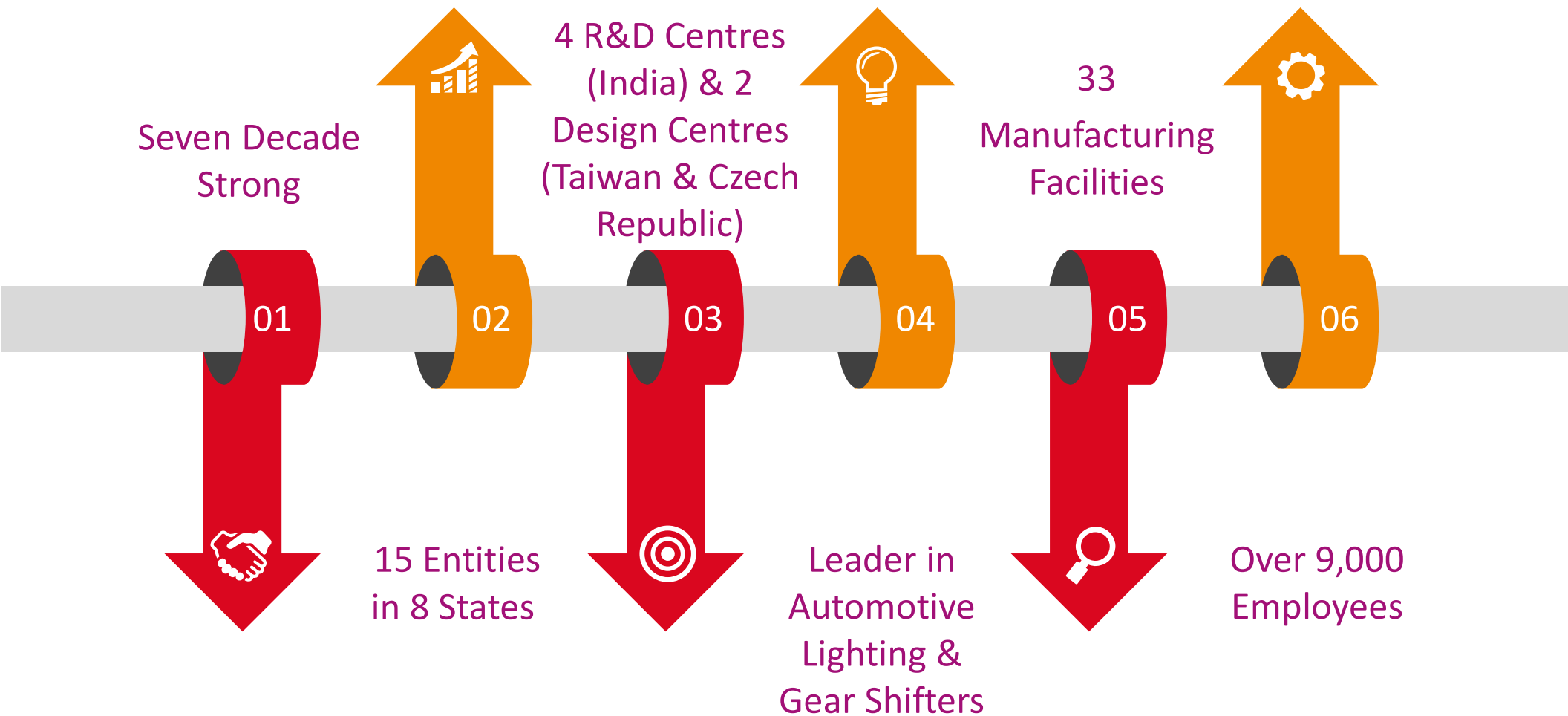

Two Listed Entities



Lumax Industries Limited

Products & Services

End-to-end Automotive
Lighting Solutions

HVAC Panels and other
electronic components

Partnerships

- Stanley – Japan
- SL Corporation - Korea

Lumax Auto Technologies Limited

Products & Services

Integrated Plastic modules, 2-wheeler Chassis, 2/3-wheeler Lighting, Gear Shifters, Emission systems, Transmission Products, Seat Frames, Aftermarket, Telematics Products and Services, Oxygen Sensors, On-board Antennas, Manufacture and supply of electric devices and components including software related to automotive industry

Partnerships

- Cornaglia – Italy
- Mannoh – Japan
- Ituran – Israel
- FAE – Spain
- JOPP – Germany
- YOKOWO – Japan
- Alps Alpine – Japan

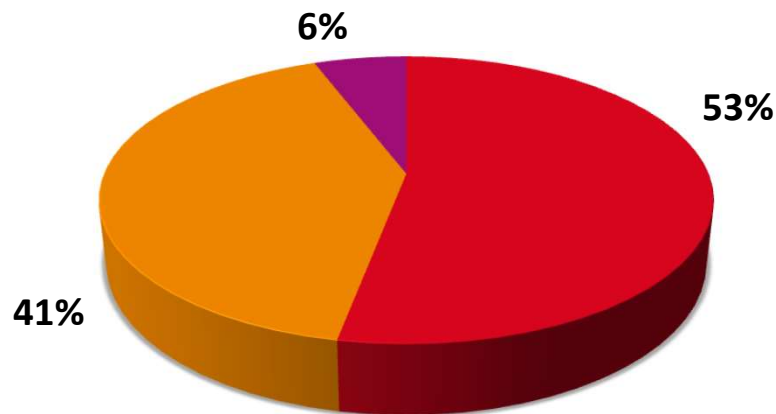

- Lumax Industries Limited
- Lumax Auto Technologies Limited
- Other Entities

FY21 Group Revenue Break Up (%)

We deliver **PRIDE** and
PROGRESS with
POSITIVITY



**Our
Group
Purpose**

Respect
Integrity
Passion
Excellence



**Our
Values**

Building an **ADMIRABLE**
HIGH PERFORMANCE
Global Organisation in
whom all stakeholders
have **ABSOLUTE TRUST**



**Our
Vision**



Diversified Product Range – 4-wheelers

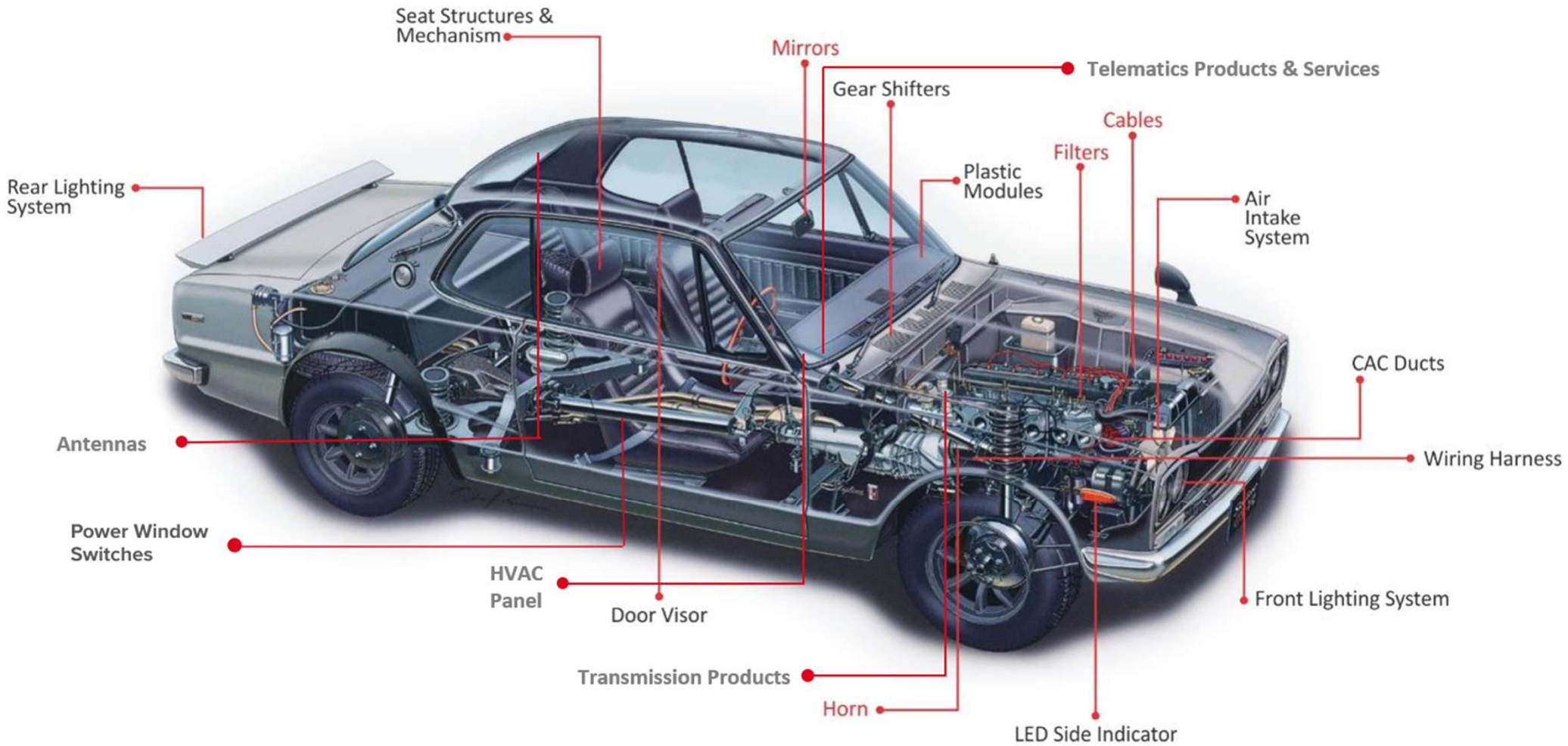

- Destination Boards & Urea Tanks for Commercial Vehicle
Aftermarket products

Diversified Product Range – 2-wheelers

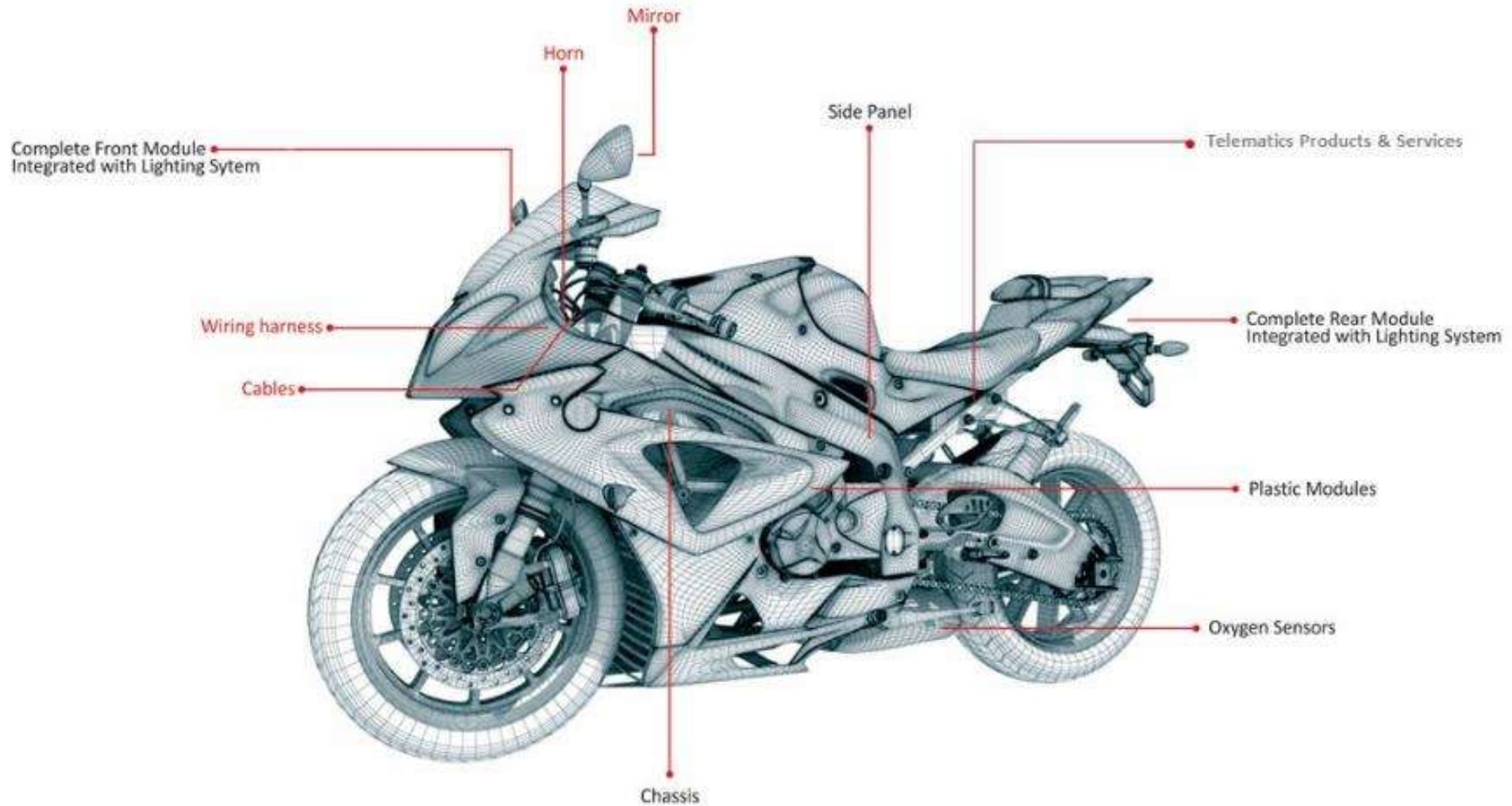

■ *Aftermarket products*

Diversified Product Range – Commercial Vehicles

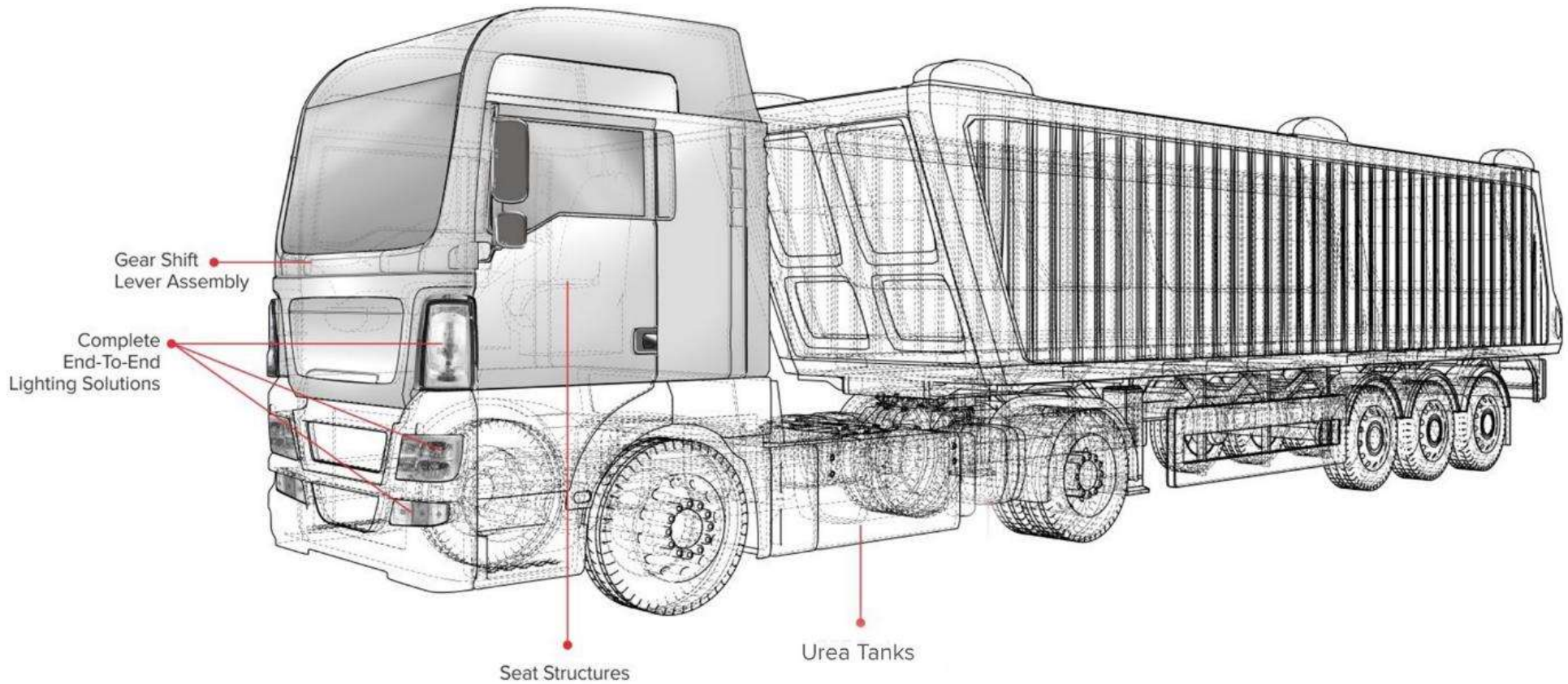

Diversified Product Range – Farm Equipment Sector (FES)

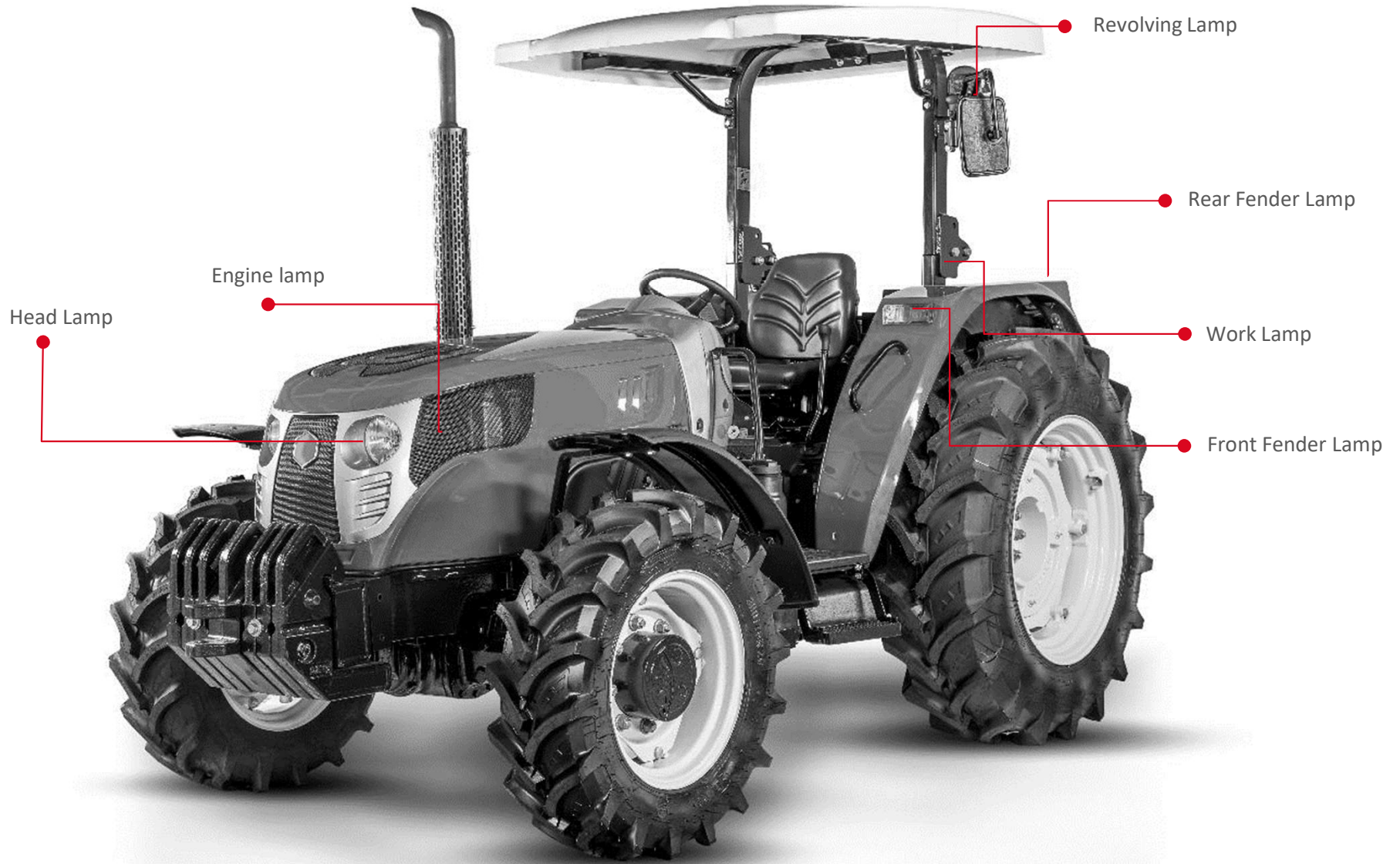

Fostering Partnerships to Deliver Excellence



Japan

Relationship Since 1984
JV for lighting, HVAC panels and other electronics
37.5% in Lumax Industries Ltd.



Korea

Relationship Since 1997
JV for lighting and other automotive parts
78.72% in SL Lumax Ltd.



Italy

Relationship Since 2007
JV for emission systems
50% in Lumax Cornaglia Auto Technologies Pvt. Ltd.



Japan

Relationship Since 2008
JV for gear shifters
45% in Lumax Mannoh Allied Technologies Ltd.



Israel

Relationship Since 2017
JV for sale of telematics products and services
50% in Lumax Ituran Telematics Pvt. Ltd.



Spain

Relationship Since 2017
JV for oxygen sensors
16% in Lumax FAE Technologies Pvt. Ltd.



Germany

Relationship Since 2019
JV for manufacture and supply of transmission products
50% in Lumax Jopp Allied Technologies Ltd.



Japan

Relationship Since 2020
JV for manufacture and supply of antennas & other vehicle communication products
50% in Lumax Yokowo Technologies Pvt. Ltd.



Japan

July 2021
JV for manufacture and supply of electric devices and components
50% in Lumax Alps Alpine India Pvt. Ltd.

33 Locations close to Customers

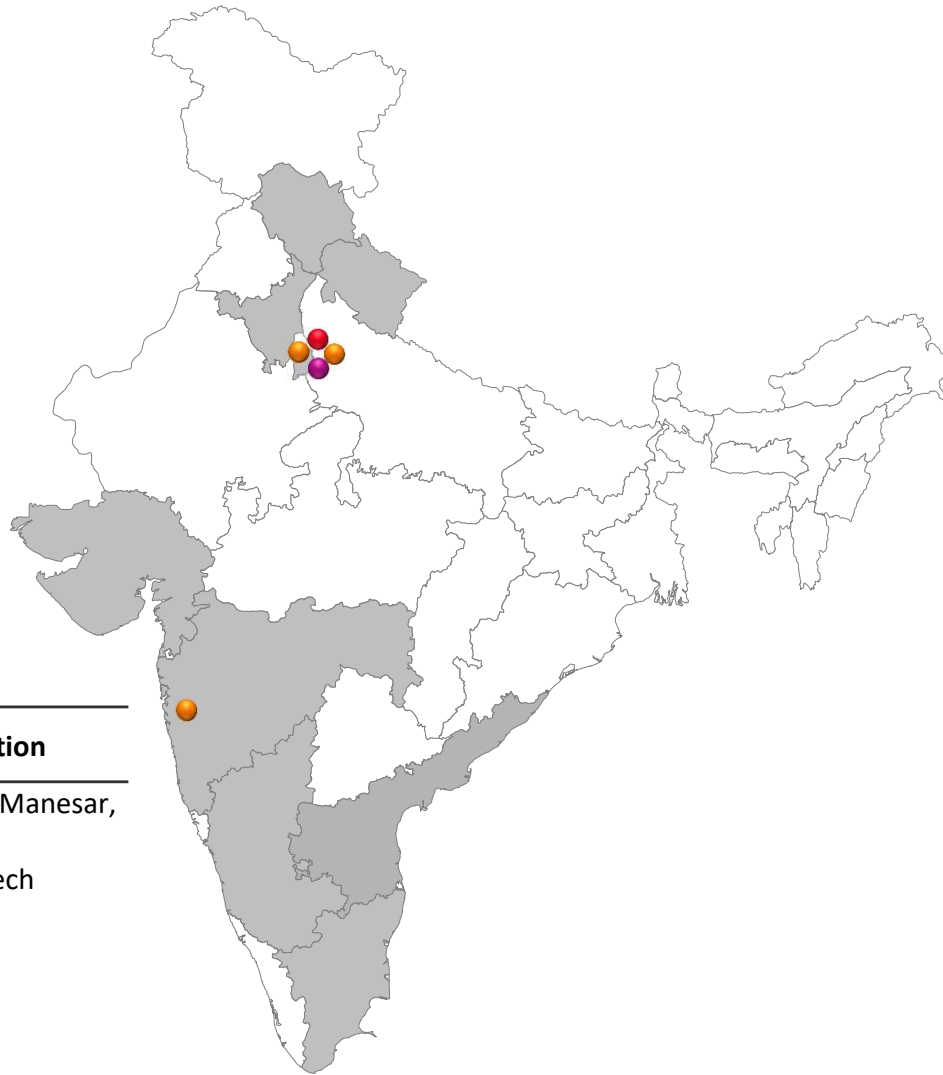

| State | Mfg Locations | # |
|------------------|---------------|-----------|
| Haryana | Bawal | 2 |
| | Dharuhera | 1 |
| | Gurugram | 4 |
| | Manesar | 3 |
| Maharashtra | Pune | 9 |
| | Waluj | 2 |
| Karnataka | Bengaluru | 2 |
| Gujarat | Sanand | 1 |
| | Mehsana | 1 |
| Tamil Nadu | Sriperumbudur | 1 |
| Andhra Pradesh | Anantapur | 1 |
| Uttarakhand | Haridwar | 1 |
| | Pantnagar | 4 |
| Himachal Pradesh | Kale Amb | 1 |
| Total | | 33 |

| Facilities | Location |
|-------------------------|-------------------------|
| ● R&D Centre | Gurugram, Manesar, Pune |
| ● Design Centre | Taiwan, Czech Republic |
| ● Corporate HQ | Gurugram |
| ● After Market Division | Gurugram |

33 Plants in 8 States

Lumax Industries Limited & Lumax Auto Technologies Limited, along with its subsidiaries, JVs & Associates



Relationships with Diversified Customers



Two Wheeler



Tier 1



Four Wheeler



Commercial Vehicle



The Brand Names mentioned are the property of their respective owners and are used here for identification purposes only

Tractor/FES



Defence & Aero Space



Export



... Strong After Market Exports Presence



Lumax Industries Limited

Leading the evolution in Automotive Lighting



Milestone

1945: Founded a partnership firm 'Globe Auto Industries' as a Trading concern

1956-57: Set-up dedicated unit for Automotive Lighting Equipment in Delhi

1977-79: Setup manufacturing units in Faridabad, Haryana and Pune, Maharashtra

1981: Lumax Industries Pvt Limited established after taking over partnership firm Globe Auto Industries

1984: TA signed with Stanley, Japan for Lighting Equipment

1985: Setup a manufacturing unit in Gurugram, Haryana. The company went public & is listed on the stock exchange

1994: Equity participation of Stanley, Japan in Lumax Industries Limited

Manufacturing unit setup in Aurangabad, Maharashtra

1997: Joint Venture agreement with SL Lumax Limited.

1998: Set-up manufacturing unit at Dharuhera, Haryana

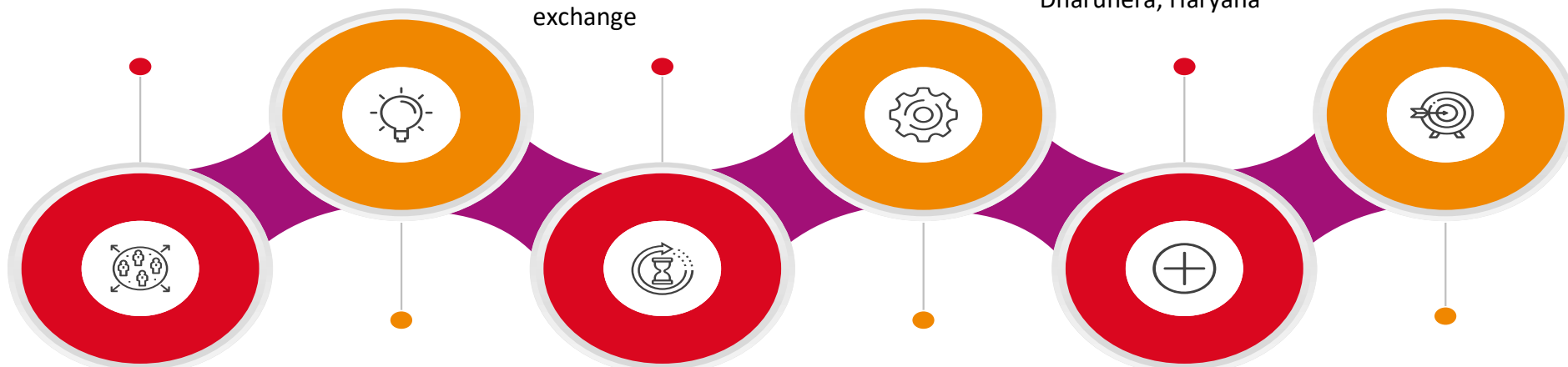

2003: Demerger Lumax Industries

2005: Setup manufacturing unit in Chakan, Maharashtra

2008: Setup manufacturing plant in Pantnagar, Uttarakhand & expansion of Dharuhera and Chakan plants. Also setup a R&D centre at Gurugram

2010: Setup a manufacturing plant in Haridwar, Uttarakhand

2011: Setup manufacturing plants in Bawal, Haryana; Sanand, Gujarat & Bidadi, Karnataka. Also setup a R&D centre at Pune

2016: Opening of **Design Centre** in Taiwan

2017: Further expansion at Sanand, Gujarat facility

2019: Commencement of Electronics Facility at Manesar

2020: Lumax Industries Ltd, India and Stanley Electric Co. Ltd., Japan extend product portfolio to include Electronics components, HVAC Panels, etc.

2021: Opening of Design office in Czech Republic

2022: Commencement of Electronics Facility at Bawal

Partnerships

With more than three & half decades of partnership with Stanley, Japan, the only global auto lighting company to manufacture LED worldwide, having presence in Japan, America, China, Asia Pacific and Europe

Technology Expertise

State-of-the-art facilities allows us to benchmark our products

Financial Stability

Consistent financial performance with improving return ratios

Market Leaders

Leadership in Lighting



Experience

Over 7 decades of OEM relationships

Product Portfolio

One of the few players with largest range of lighting solutions & Electronics

In-House Design

2 R&D centers & 2 Overseas Design centers to stay ahead of the curve in design trends

Proximity to Customers

12 manufacturing facilities strategically located at key automotive hubs in the country

Customer Mix Q3 FY22



Rs. in Crores

Customer wise Sales Q3FY21 (Rs.435 Crores)*

Q3 FY21

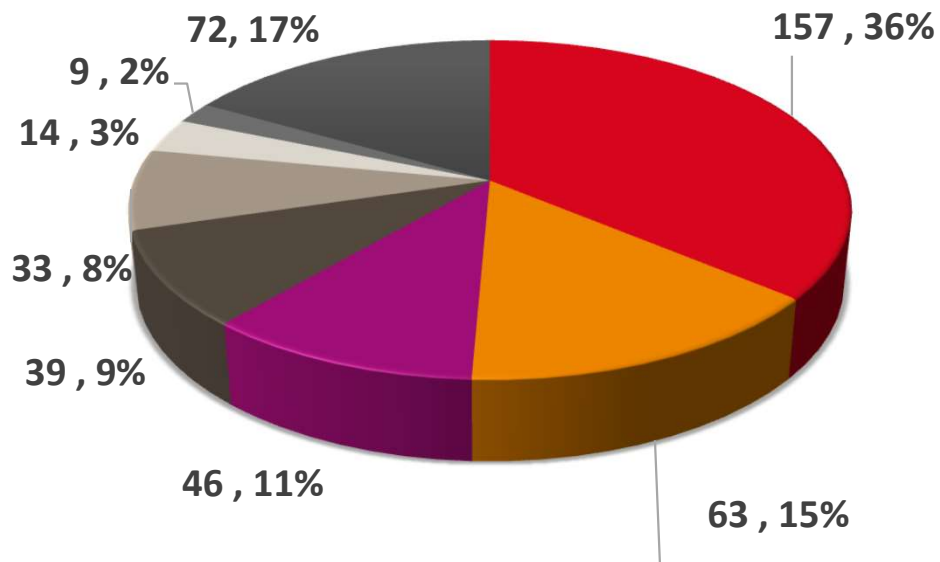

- MSIL/SMG
- HMSI
- HML
- M&M
- TATA
- HCIL
- TVS
- Others

Customer wise Sales Q3FY22 (Rs.431 Crores)*

Q3 FY22

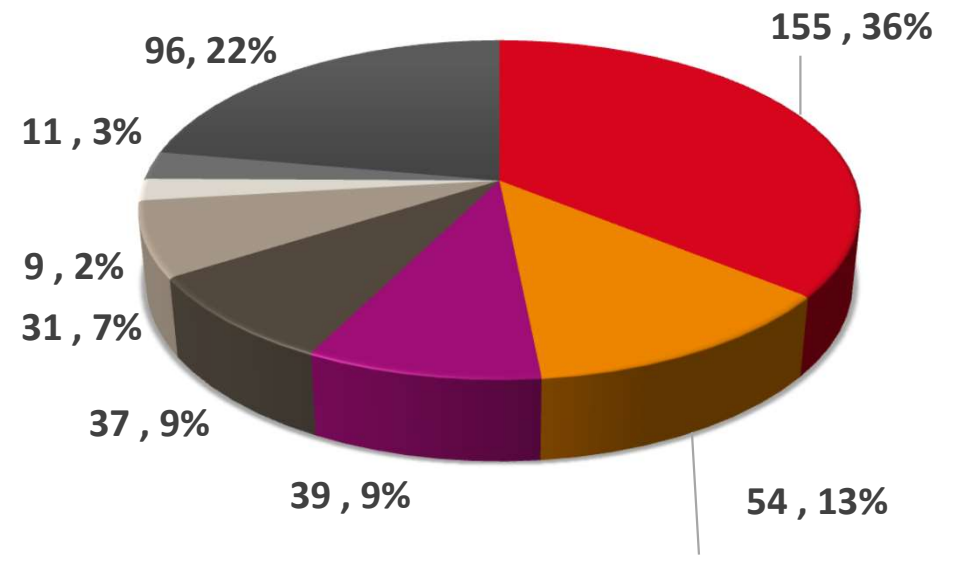

- MSIL/SMG
- HMSI
- HML
- M&M
- TATA
- HCIL
- TVS
- Others

*Excludes Mould Sales

Customer Mix 9M FY22



Rs. in Crores

Customer wise Sales 9MFY21 (Rs.885 Crores)*

9M FY21

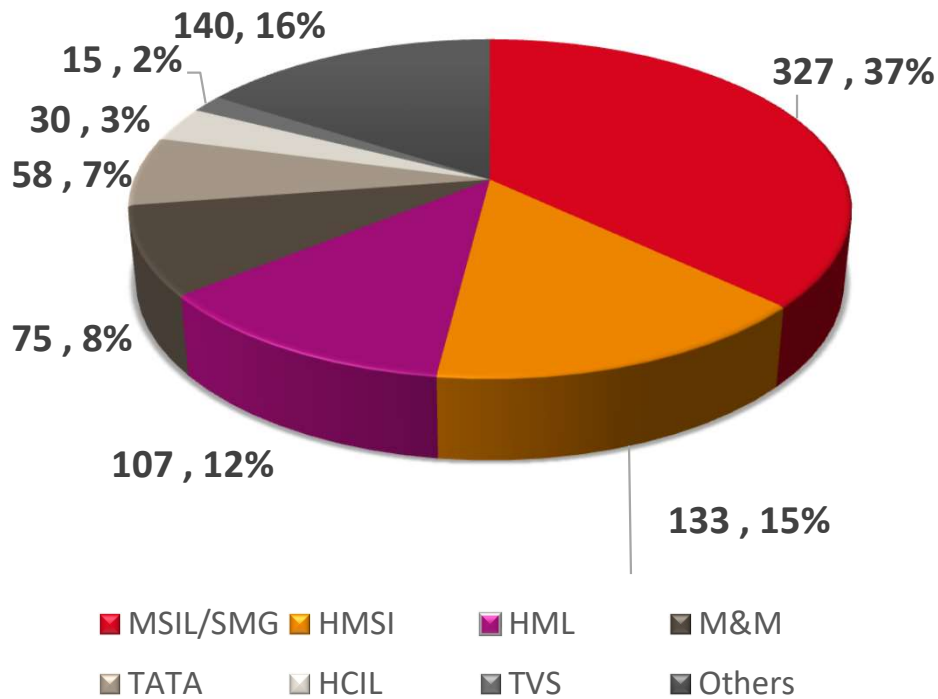

Customer wise Sales 9MFY22 (Rs.1,171 Crores)*

9M FY22

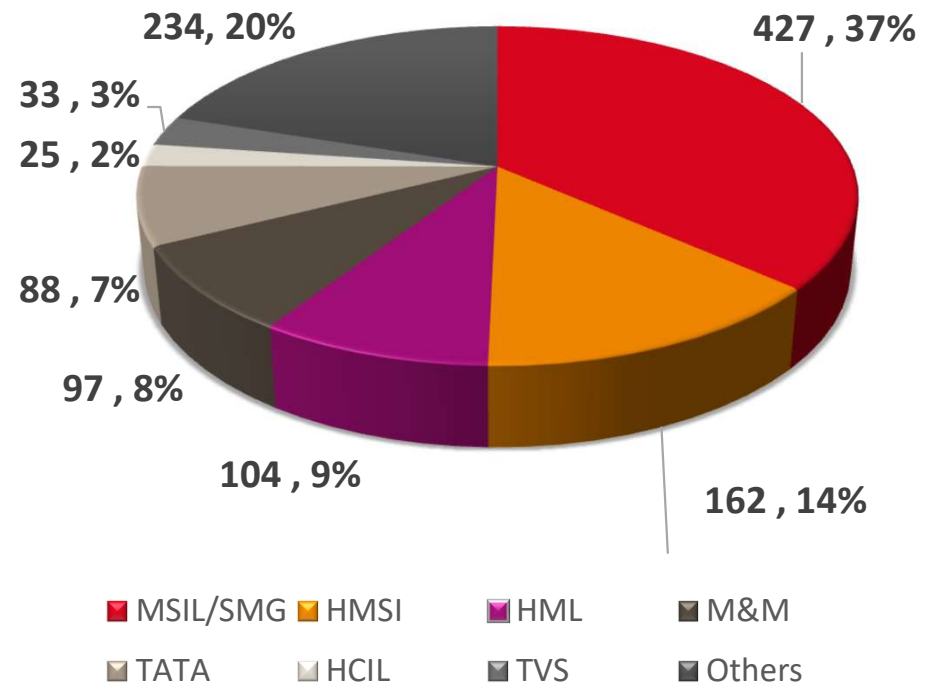

*Excludes Mould Sales

Break-up of Revenue Q3 FY22



Q3 FY22

Segment Mix

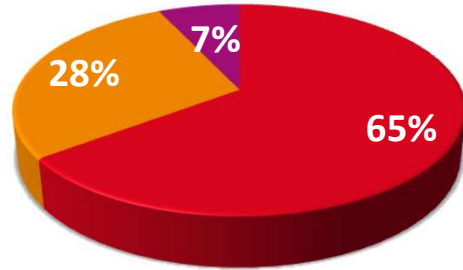

Passenger Vehicle Two Wheeler
Commercial Vehicle

LED vs Conventional

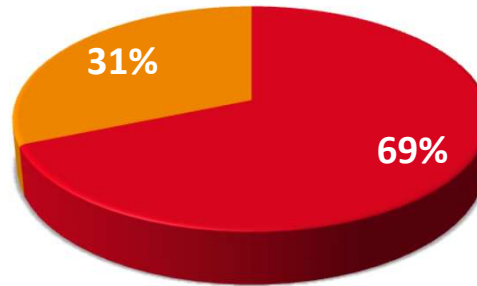

Conventional Light LED Light

Product Mix

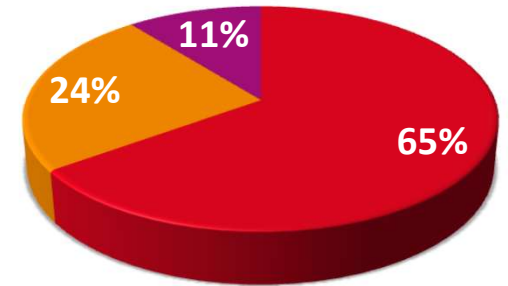

Front Lighting Rear Lighting Others

Q3 FY21

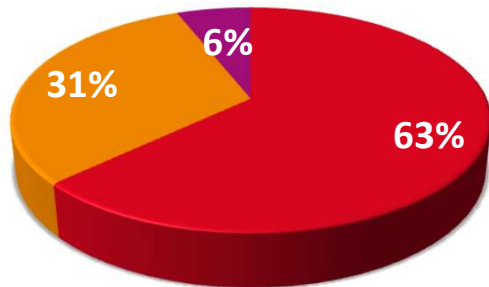

Passenger Vehicle Two Wheeler
Commercial Vehicle

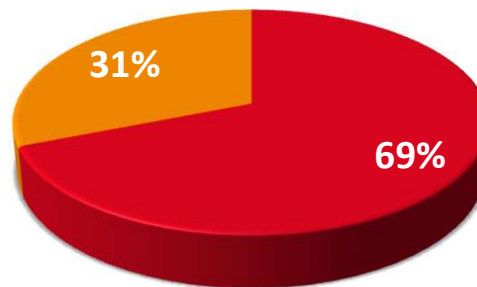

Conventional Light LED Light

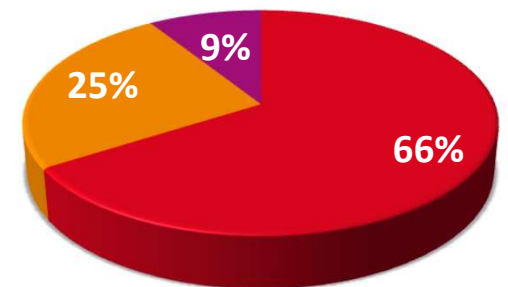

Front Lighting Rear Lighting Others

Break-up of Revenue 9M FY22



9M FY22

Segment Mix

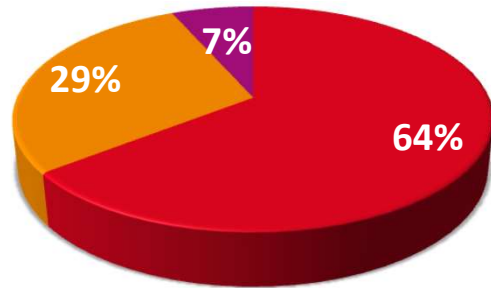

- Passenger Vehicle
- Two Wheeler
- Commercial Vehicle

LED vs Conventional

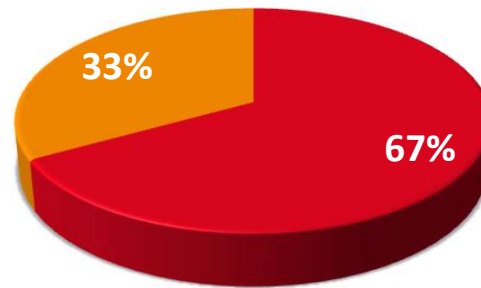

- Conventional Light
- LED Light

Product Mix

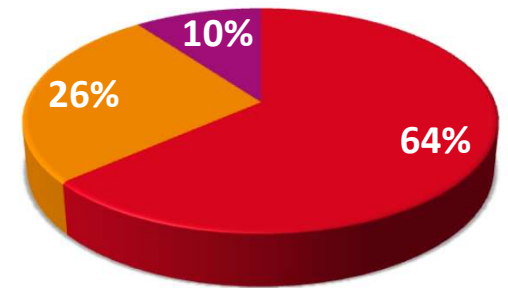

- Front Lighting
- Rear Lighting
- Others

9M FY21

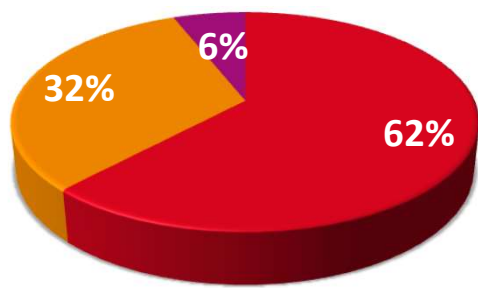

- Passenger Vehicle
- Two Wheeler
- Commercial Vehicle

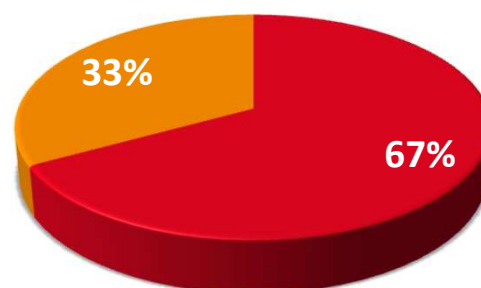

- Conventional Light
- LED Light

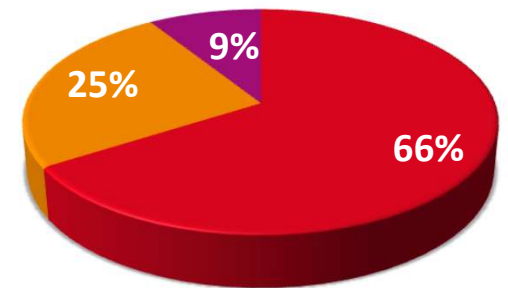

- Front Lighting
- Rear Lighting
- Others



Established in 1997



Associate Company with 21.28% holding

In partnership with SL Corporation, Korea, a multinational automotive player with presence in Asia-Pacific, Europe & US



Plants in Sriperumbudur near Chennai and Anantapur in Andhra Pradesh



Products

Lamps

Head Lamp, Rear Combination Lamp, Fog Lamp

Others

Chassis, Trim & Mirrors

Shift Lever, Parking Brakes



FY21 Sales

Rs. 1,477 Crores



Key Customers



Strong Customer Base ...



Four Wheeler



Two Wheeler



PIAGGIO®



Commercial Vehicle



DAIMLER



Export



Tractor /FES



... Servicing almost 90% of OE Customers in India ...

The Brand Names mentioned are the property of their respective owners and are used here for identification purposes only

... From Strategic Locations ...

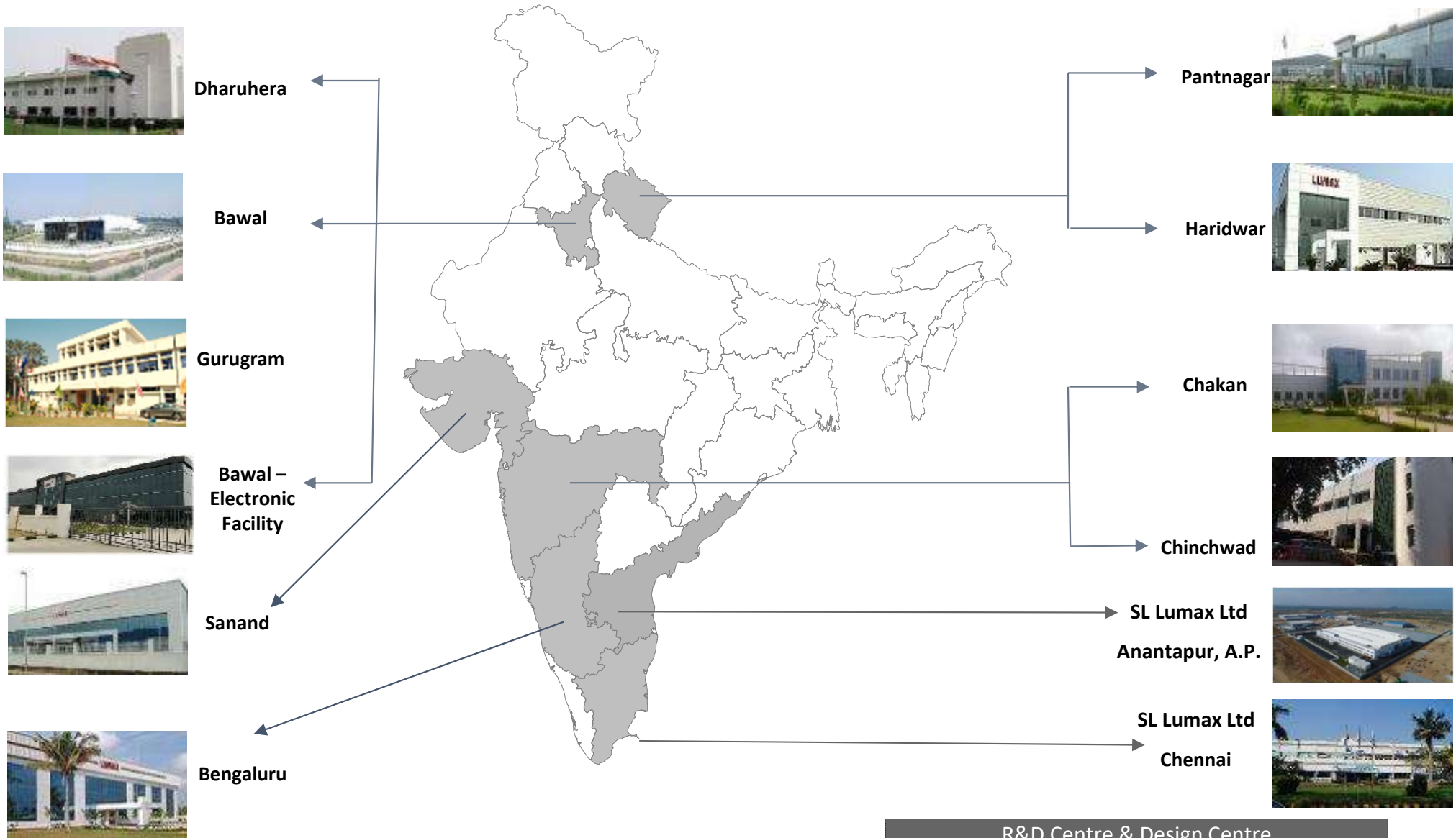

... in Key Auto Belts of India

| R&D Centre & Design Centre | |
|----------------------------|-------------------------|
| R&D Centre | Gurugram |
| | Pune |
| Design Centre | Taiwan & Czech Republic |



Shareholding Breakup

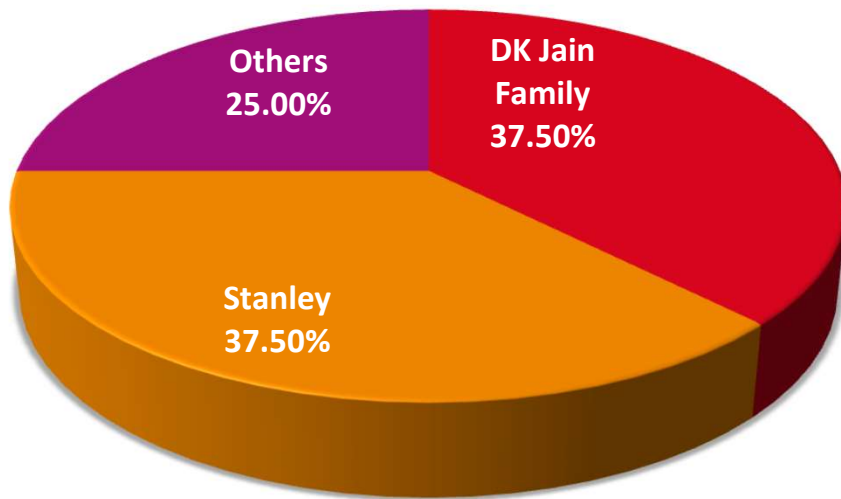

Stanley Electric Company Ltd

- Over three and a half decades of strong technical & financial collaboration with Stanley Electric Company Ltd, Japan
- A world leader in Vehicle Lighting & Illumination products for Automobiles
- The only Global Auto Lighting company to manufacture LED worldwide



Mr. Dhanesh Kumar Jain
Chairman Emeritus

- He is 79 years of age & holds a MBA degree from Delhi university & has successfully completed President Management Program from Harvard Business School
- Over 50 years of experience in the automotive industry in management, operations & administrative roles
- He has held various industry positions
 - Past president of ACMA, president suppliers association – Toyota Kirloskar Motors, Chairman of Trade Fairs Committee ACMA, Co-chairman of Regional Committee on Membership of Northern Region CII, Past Chairman of CSR sub-committee of the Northern Region of CII



Mr. Deepak Jain
Chairman & Managing Director

- He is 46 years of age & is a Business Graduate from Illinois Institute of Technology, USA with specialization in Operations Management & International Business
- He has undergone extensive training at Stanley Co. Limited, U.S.A. & Stanley Electric Co. Limited, Japan. He has over 25 years experience
- He is the immediate Past President of ACMA, he was chairman of ACMA's HR/IR & Skill Development Committee, past chairman of Sustainable Technology Development Committee of ACMA, past National Coordinator of Young Business Leader Forum of ACMA and past president of Supplier's club, Honda Cars India Limited.
- He is also Chairman - CII Northern Region - Regional Committee on Advanced Manufacturing and is member of Young President's organization and Entrepreneurs organization. He also holds the position of Vice President of Toyota Kirloskar Supplier's Association



Mr. Anmol Jain
Jt. Managing Director

- He is 42 years of age & holds Bachelors in Business Administration in Finance & Supply Chain Management (Double major) from Michigan State University, U.S.A.
- He worked as a Management Trainee with GHSP, U.S.A. & subsequently, joined Lumax Group, in 2000 & has over 20 years of experience
- He has held various positions in Industry associations - He was the National Coordinator of ACMA- YBLF from 2014-16. He was also the Chairman CII Haryana State Council in 2012-13
- He is currently the President of Honda Cars India Supplier's Club & MC member of Bajaj Auto Vendor Association and Executive Council member of ACMA



Mr. Tadayoshi Aoki

Senior Executive Director

- He is 55 years old & is a Mechanical Engineering from Tokoyo Denki University Japan
- He is Nominee Director of M/s Stanley Electric Co. Limited, Japan and possesses over 28 years of rich experience in the field of Car Electronics, Engineering, Sales of car electronic parts and Sales Planning Division
- He is with Lumax since 2017



Mr. Toru Tanabe

Non-Executive Director

- He is 62 years old & is a graduate from Hosei university, Japan
- He has over 25 years of rich experience in R&D of Electrical components & advanced Illumination systems for automotive equipment
- He also has about 10 years of experience in automotive electronics
- He joined Stanley, Japan in 1981



Mr. Kenjiro Nakazono

Executive Director

- He is 51 years old & is a graduate from graduate from Hamamatsu Commercial High School
- He has over 30 years of rich experience in Procurement, Planning, Audit and NPD

...Supported by Strong Independent Directors



Mr. A P Gandhi

Age: 83 years

Mechanical Engineer

He has held top leadership positions in prestigious organisations such as President at Hyundai Motors India Limited , Chief Executive – R&D at Escorts Limited & at Telco and having over 40 years of experience.



Mr. Rajeev Kapoor

Age: 69 years

Mechanical Engineer (hons) from NIIT, Kurukshetra

He is Ex-President and CEO of Fiat India Automobiles Limited, MD for Copart Inc. and has served as Co-Chair of Economic Committees SIAM, served on the board of ARAI, Pune, and on the board of the Indo Italian chamber of Commerce. He has over 45 years of experience



Mr. Dhiraj Dhar Gupta

Age: 71 years

B.Com honours from SRCC, Delhi University

He is an Industrialist having over 3 decades of experience in Auto Component manufacturing.



Mr. Rattan Kapur

Age: 64 years

B.Com Graduate from Delhi University

He is an Industrialist & possesses more than 32 years of experience in Auto Component Industry. He is the Past President of ACMA & Chairman of Haryana State Council of CII.



Ms. Ritika Modi

Age: 55 years

She has an industry experience of over 25 years in the travel and airline industry. She is currently Regional President of UNIGLOBE Travel South Asia, heading the largest single brand travel franchise network in South Asia region.



Mr. Vikrampati Singhania

Age: 56 years

MBA from Fuqua School of Business, Duke University, USA

He is currently MD of JK Fenner (India) & JK Agri Genetics having an experience of over 27 years in industry. He is a 4th generation industrialist from the industrial group- JK Organisation.

Professional & Experienced Team

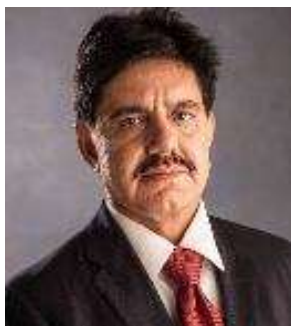

Mr. Vineet Sahni
CEO & Sr Executive Director
Age: 56 years
Experience: over 30 Years



Mr. Sanjay Mehta
Group CFO
Age: 54 years
Experience: 29 Years

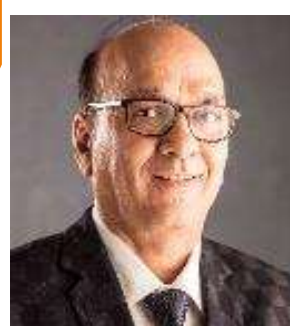

Mr. Naval Khanna
Corporate Head – Taxation
Age: 63 years
Experience: 43 years



Mr. Todd Morgan
Chief Technology &
Innovation Officer
Age: 54 Years
Experience: 27 Years



Mr. Shrutikant Rustagi
Chief Financial Officer
Age: 50 Years
Experience: 25 Years



Mr. Atul Jain
Corporate Head - Materials
Age: 50 Years
Experience: 27 Years



Ms. Priyanka Sharma
Corporate
Communication
Age: 53 Years
Experience: 26 Years



Mr. Raajesh Kumar Gupta
Group Company Secretary
Age: 51 Years
Experience: 28 Years



Mr. Pankaj Mahendru
Company Secretary
Age: 35 Years
Experience: 10 Years

The Path Ahead



Rear Lamp – Technology Evolution



2014 - 2016

- Penetration of LED's into Tail Lamps with introduction of one or more feature with LED.
- LED's adopted for giving Signature shape in the Tail Lamps
- Almost all the new models launched were having presence of LED's either for one of the functions or for Signature Lighting

2017

- Moving from just LED tail to full LED rear lamp applications allowing for compact functionality and a product that meets "life of vehicle" durability. Provides appearance that signature effects that are not possible using conventional bulb technology

2020-23

- Animated functionality including gliding/progressive turn indicator for improved safety, and welcome/goodbye sequences that provide a unique customer experience when locking and unlocking their vehicles

2022-24

- Diffractive Optics that provide an innovative 3D effect, or ultra-homogeneous appearance with high efficiency by utilizing precision micro-optics.
- Provides customer with creative appearance, and optimizes energy consumption

2025 & beyond

- OLED (Organic LED)... Ultra thin and homogeneously lit optical elements that be pixelized, allowing for personalization, animation and communication



Head Lamp – Technology Evolution



2014-17

- Introduction of Projector Lamps with Halogen Bulbs for new vehicles launched in India by more number of OEM's as standard feature
- In 2015 more number of Head Lamps were introduced with LED's for DRL feature with usage of HID (High Intensity Discharge) Bulbs for Projector, OEMs shifted focus to LED
- Headlamps with Signature DRL's or Lighting become a styling feature and were introduced in the vehicles launched in 2016
- Later half of 2016 also witnessed the introduction of LED Projector Head Lamps thus leading to more penetration of Electronics and LED into Head Lamps
- Year 2017 witnessed the transition to manufacturing of Localized LED Head Lamp with Signature DRL and Position



2019-21

- Increasing presence of LED headlamps. LED projectors are the most desired appearance, to give a "high tech look".
- LED offers a scalable performance with high color temperature, and significantly lower power consumption compared to halogen.
- Low profile designs are now possible, giving studios unprecedented styling freedom

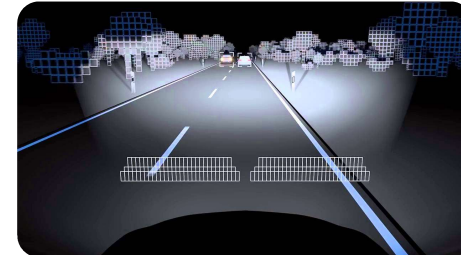

2022 onwards

- LED will continue to replace halogen, with some vehicle lines completely removing the halogen option.
- Also advanced functionality will become increasingly present, including AFS functionality that allow the beam to swivel based on steering wheel angle, and other sensors on the vehicle.
- Finally ADB (Adaptive Driving Beam) or Matrix headlamps will begin to appear in the Indian market. This technology makes use of on-board cameras to detect oncoming or following traffic to adapt the beam allowing the driver to use high beams without glaring other drivers.

State of Art Manufacturing Facilities



...In-house R&D & Validation Facility

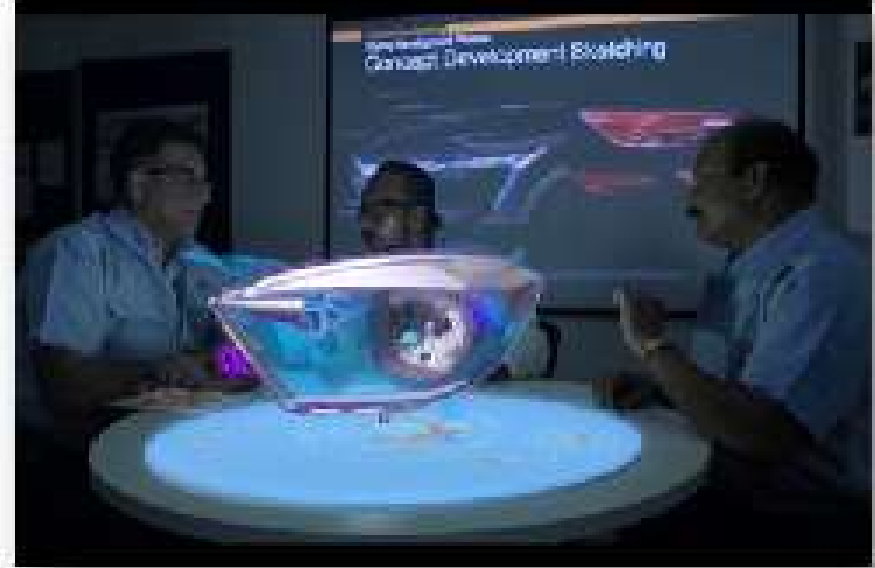



Financials



Strong Growth in Total Income with Healthy Margins



Standalone Results

Revenue

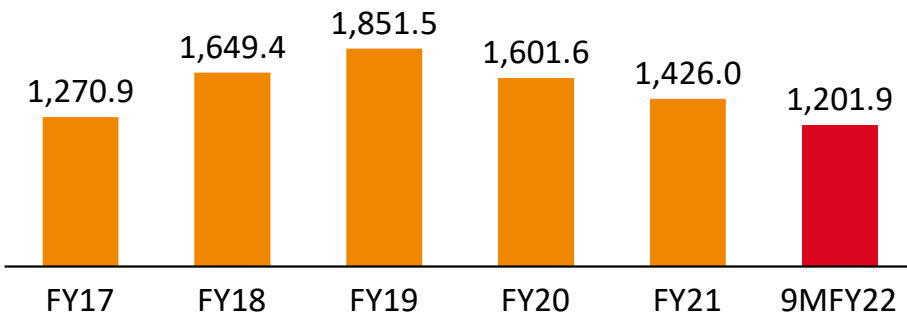

Reported EBITDA[#]

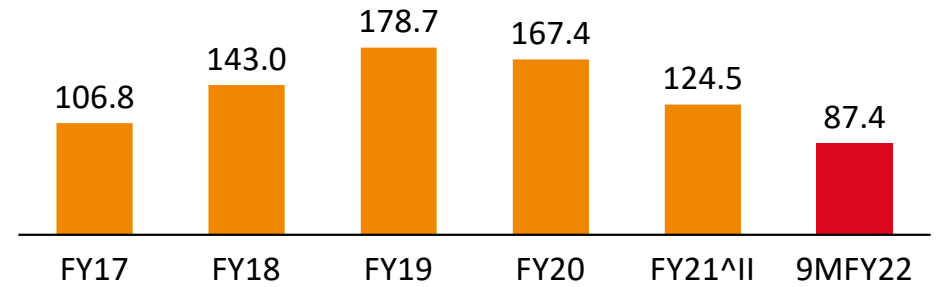

PAT

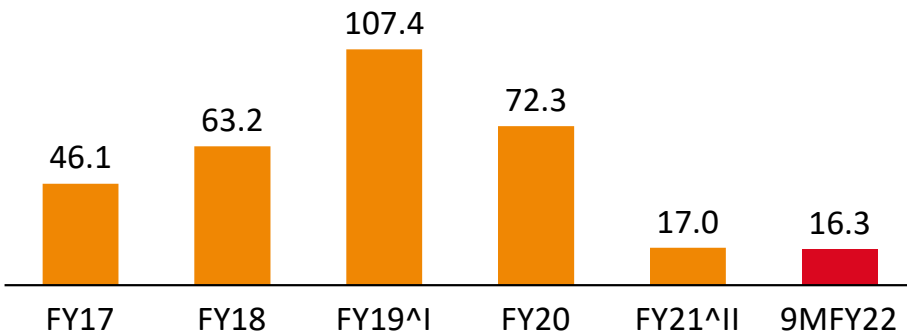

Cash PAT

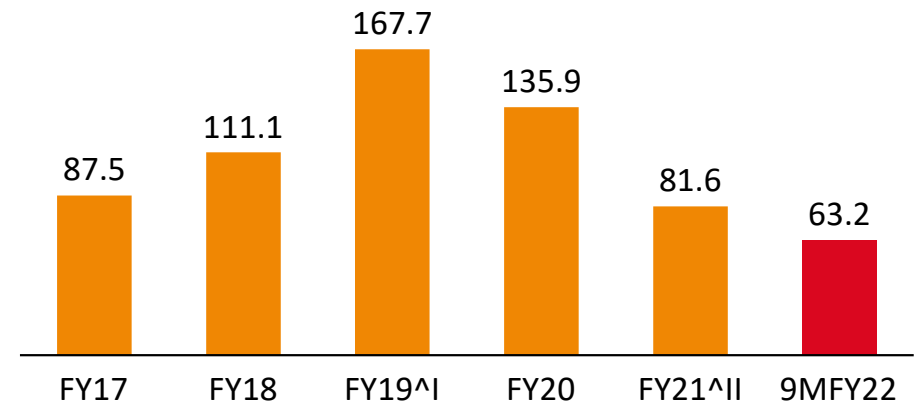

Including Other Income
Rs. Crores

^{^I} - Includes one-time gain on sale of asset of Rs. 36.20 Crores and the tax paid on the same was Rs. 7.20 Crores, in FY19

^{^II} - FY21 EBITDA includes Rs. 12 cr. subsidy income

9MFY22 EBITDA & PAT is excluding exceptional expense of Rs. 10.35 cr on account of VSS, tax amount on same is Rs.3.36 cr

Expansion funded through Internal Accruals



Standalone Results

Gross Block

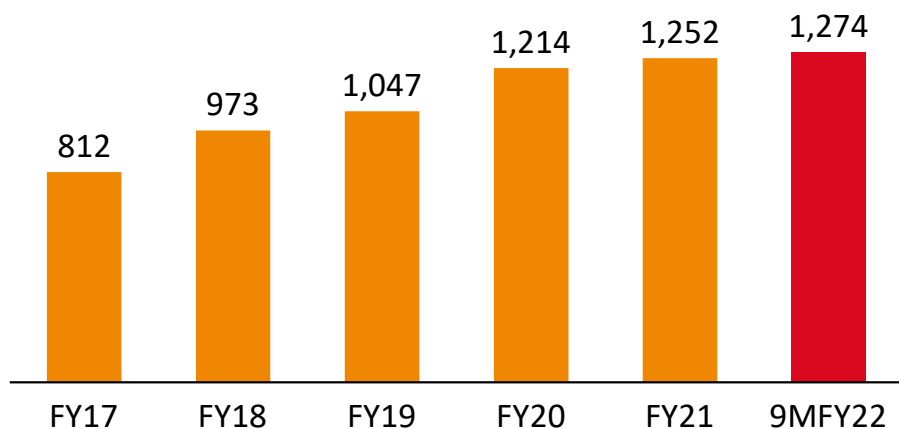

Long Term Loan

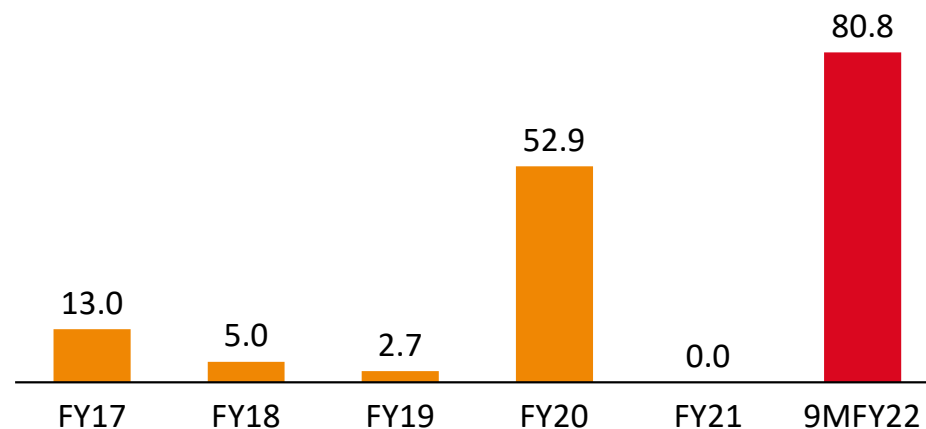

Capex

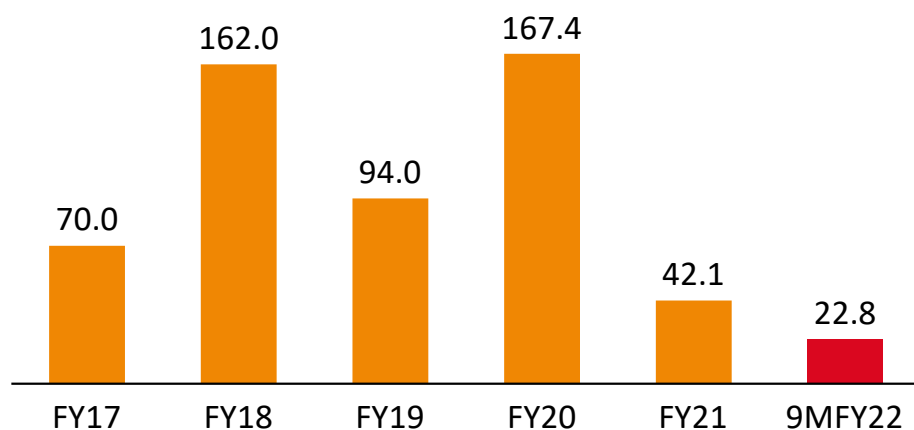

Long Term Debt / Equity

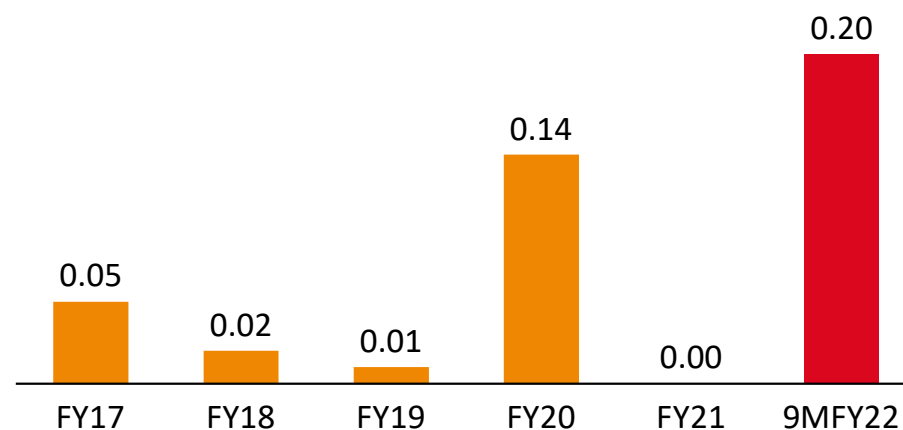

Healthy Return Ratios



Standalone Results

ROE (%)

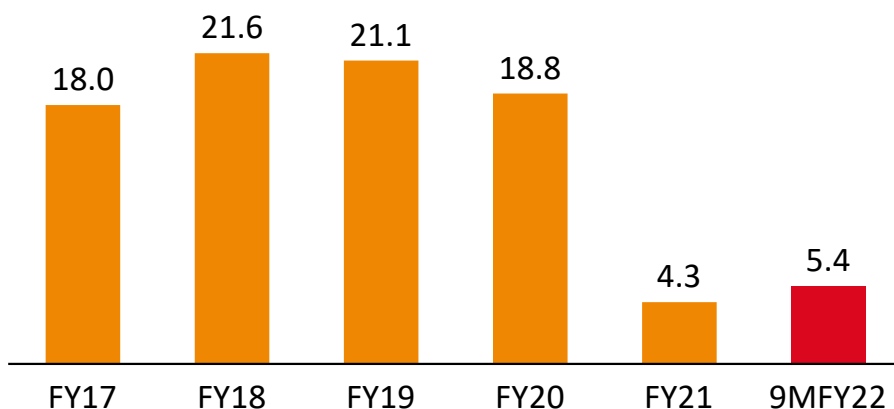

ROCE (%)

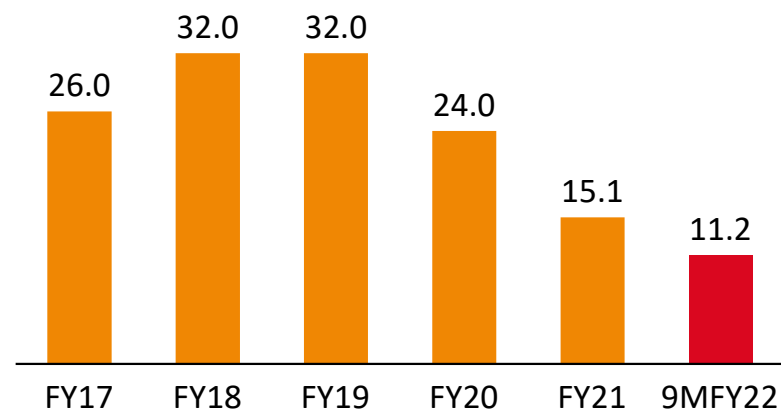

Dividend (% of Face Value)

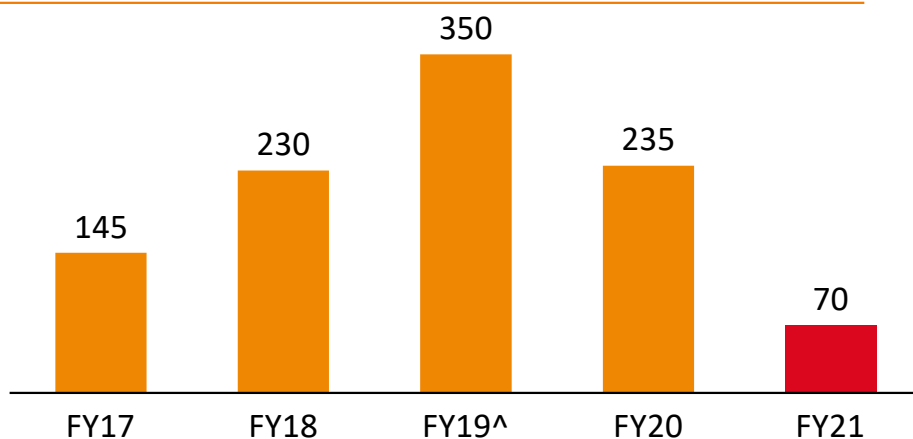

EPS (in Rs.)

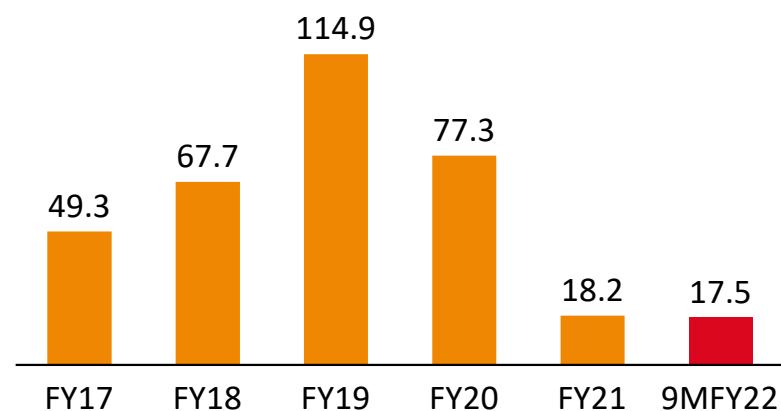

[^] Total Dividend includes special dividend of Rs. 10/share on account of income on sale of land and building in FY19

9MFY22 EPS is excluding exceptional expense of Rs. 10.35 cr on account of VSS, tax amount on same is Rs.3.36 cr

ROCE = EBIT / Capital Employed

Capital Employed = Networth + Long term debt including Current Maturity



Consolidated P&L Statement



| Particulars (Rs. in Crores.) | Q3 FY22 | Q3 FY21 | Y-o-Y | 9M FY22 | 9M FY21 | Y-o-Y |
|---|--------------|--------------|---------------|----------------|--------------|---------------|
| Manufacturing Revenue | 431.0 | 434.9 | -0.9% | 1,170.9 | 884.7 | 32.4% |
| Molds Revenue | 4.3 | 11.4 | | 31.1 | 36.9 | |
| Total Operating Revenue | 435.3 | 446.2 | -2.5% | 1,201.9 | 921.6 | 30.4% |
| Other Income | 3.3 | 1.9 | | 9.9 | 9.4 | |
| Total Income | 438.6 | 448.1 | -2.1% | 1,211.8 | 931.0 | 30.2% |
| Raw Material | 274.6 | 278.5 | | 764.8 | 584.8 | |
| Employee Expenses | 63.0 | 56.9 | | 181.2 | 142.9 | |
| Other Expenses | 63.4 | 62.9 | | 178.4 | 144.3 | |
| EBITDA | 37.6 | 49.8 | -24.6% | 87.4 | 59.0 | 48.1% |
| EBITDA Margin | 8.6% | 11.2% | | 7.3% | 6.4% | |
| Depreciation | 15.4 | 17.2 | | 46.9 | 47.5 | |
| Finance Cost | 5.1 | 6.8 | | 16.7 | 22.9 | |
| PBT before Tax, Exceptional items & share of profit/ (loss) of associate | 17.1 | 25.8 | -33.7% | 23.8 | -11.3 | 309.9% |
| Exceptional items | 10.4 | 0.0 | | 10.4 | 0.0 | |
| Profit from Associate | 2.9 | 9.5 | | 4.0 | 2.5 | |
| Profit before Tax & after Exceptional items & Share of Associate | 9.6 | 35.3 | -72.7% | 17.4 | -8.8 | 297.9% |
| Tax | 2.8 | 15.4 | | 5.2 | -4.3 | |
| Profit after tax | 6.8 | 19.8 | -65.8% | 12.2 | -4.6 | 368.2% |
| PAT Margin | 1.6% | 4.4% | | 1.0% | -0.5% | |
| EPS | 7.25 | 21.20 | | 13.06 | -4.87 | |

Consolidated Balance Sheet



| ASSETS (Rs. in Crores) | Sep-21 | Mar-21 | EQUITY & LIABILITIES | Sep-21 | Mar-21 |
|---|----------------|----------------|--|----------------|----------------|
| Non-current assets | | | Equity | | |
| Property, plant and equipment | 565.2 | 581.2 | Equity Share capital | 9.3 | 9.3 |
| Capital work-in-progress | 113.3 | 47.0 | Other equity | 450.9 | 451.1 |
| Right of use assets | 29.8 | 30.7 | Sub-total - Shareholders' funds | 460.3 | 460.4 |
| Investment property | 0.7 | 0.7 | LIABILITIES | | |
| Goodwill | 9.8 | 9.8 | Non-current liabilities | | |
| Intangible assets | 3.7 | 4.7 | Financial liabilities | | |
| Intangible assets under development | 3.2 | 0.0 | Borrowings | 65.8 | 0.01 |
| Investments accounted using the equity method | 91.8 | 90.3 | Lease liability | 36.0 | 36.2 |
| Financial assets | | | Provisions | 34.5 | 32.0 |
| Investments | 2.7 | 1.6 | Deferred tax liabilities (net) | 34.0 | 32.8 |
| Loans | 0.7 | 0.8 | Sub-total - Non-current liabilities | 170.3 | 101.0 |
| Others | 7.9 | 7.8 | Current liabilities | | |
| Other tax Assets | 9.0 | 5.0 | Financial liabilities | | |
| Other non-current assets | 62.9 | 72.0 | Borrowings | 321.7 | 300.9 |
| Sub-total - Non-Current Assets | 900.7 | 851.7 | Lease liability | 1.2 | 1.0 |
| Current assets | | | Trade payables | 345.1 | 374.4 |
| Inventories | 257.2 | 222.3 | Other financial liabilities | 104.9 | 74.4 |
| Financial assets | | | Other current liabilities | 66.1 | 41.4 |
| Investments | 0.3 | 0.2 | Provisions | 8.2 | 8.7 |
| Trade receivables | 212.0 | 216.3 | Sub-total - Current liabilities | 847.1 | 800.9 |
| Cash and cash equivalents | 1.6 | 2.8 | TOTAL - EQUITY AND LIABILITIES | 1,477.7 | 1,362.4 |
| Bank balances other than Cash | 9.2 | 0.3 | | | |
| Loans | 1.0 | 0.9 | | | |
| Others | 30.1 | 32.4 | | | |
| Other current assets | 65.5 | 35.3 | | | |
| Sub-total - Current Assets | 577.1 | 510.6 | | | |
| TOTAL - ASSETS | 1,477.7 | 1,362.4 | | | |



Awards & Recognitions



Supplier Recognition Award



Winner of the Best Delivery Management Award at the 22nd **HMSI** Supplier Convention 2021 in March 2021



Bengaluru facility was recognised for its outstanding contribution by achieving Zero Defect Supplies for the year 2020 by **Toyota Kirloskar Motor Pvt. Ltd.** in 2021



Won the Overall Performance (Shield) Award from **Maruti Suzuki India Limited** in May, 2019



- JIPM Award for Excellence in Consistent TPM Commitment Pantnagar Plant, 2019
- Dharuhera Plant won JIPM-TPM award for excellence in Category A for year 2019
- JIPM-TPM Excellence Award Bengaluru Plant, 2019
- JIPM-TPM Excellence Award Bawal Plant, November 2017
- JIPM-TPM Excellence Award Pantnagar Plant, March 2014



Dharuhera

- Won the Gold Award in Excellence in **Inclusive Growth** - A Make in India Drive - Very Large Category
- Won the Bronze Award in Excellence in **Manufacturing** - Very Large Category



Chakan won the Silver Award in Excellence in New Product Design & Development



Pantnagar won the Gold Award in Excellence in Supplier Development - Very Large Category

Awards & Recognition

- Won the prestigious Gold award for Top 100 best annual report for excellence within its industry for FY 2018-19 & 2019-20
- Lumax Industries Limited bagged The Gold Award at ICQCC for the third year in a row in FY20
- Each of our plants located at Haridwar, Bawal & Bengaluru have been accorded with this prestigious award



3 Years in a Row
ICQCC Champions
Lumax DK Jain Group



2019/20 VISION AWARDS ANNUAL REPORT COMPETITION

LUMAX INDUSTRIES LIMITED
SGA Adsvita Communique

is recognized for developing one of the
Top 100 Reports Worldwide
ranking of 135 among all reports reviewed for the past fiscal year.

Tyson Heyn
Tyson Heyn
Principal

Christine Kennedy
Christine Kennedy
Competition Director

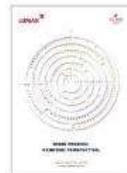

131



2019/20 VISION AWARDS ANNUAL REPORT COMPETITION

LUMAX INDUSTRIES LIMITED
SGA Adsvita Communique

is presented with the
Gold Award

for excellence within its industry on the development of the organization's annual report for the past fiscal year.

Tyson Heyn
Tyson Heyn
Principal

Christine Kennedy
Christine Kennedy
Competition Director

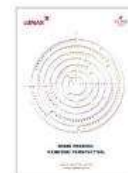

131



2019/20 VISION AWARDS ANNUAL REPORT COMPETITION

LUMAX INDUSTRIES LIMITED
SGA Adsvita Communique

is recognized for developing the
Best Report Cover
Bronze
worldwide for the past fiscal year.

Tyson Heyn
Tyson Heyn
Principal

Christine Kennedy
Christine Kennedy
Competition Director

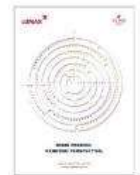

131



Social Initiatives by Lumax group towards 'Quality Education' for the society





Social Initiatives by Lumax group towards 'Good Health' for the society



For further information, please contact:

Company:

Investor Relations Advisors:



Lumax Industries Limited

CIN: L74899DL1981PLC012804

Ms. Priyanka Sharma

priyanka.sharma@lumaxmail.com

www.lumaxindustries.com

www.lumaxworld.in/lumaxindustries



Strategic Growth Advisors Pvt. Limited

CIN: U74140MH2010PTC204285

Mr. Shogun Jain / Ms. Akashi Modi

shogun.jain@sgapl.net / akashi.modi@sgapl.net

Tel: +91 77383 77756 / +91 96198 96128

www.sgapl.net